

Pressure reducing valve 315.2

made of hot-pressed brass with outlet pressure indicator

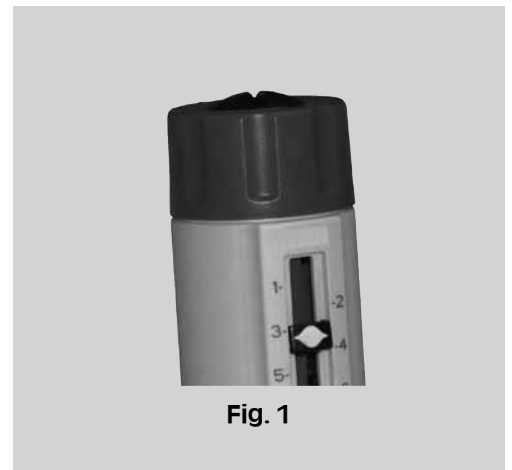

Fig. 1

Field of application

The pressure reducing valve type 315.2 is predominantly used in potable water installations in accordance with EN 806-2. Under consideration of its specifications, it also protects industrial and commercial installations against excess supply pressure. The pressure reducing valve type 315.2 protects water-supplying installations by

compensating and optimising upstream pressure variations and therefore it effectively prevents damage that can be caused by pressure increase. Furthermore, it economically and ecologically reduces the water consumption. The type 315.2 meets the highest European acoustic protection requirements.

Design

The pressure reducing valve type 315.2 is equipped with an outlet pressure indicator (see figure 1) that displays the set pressure. An additional pressure gauge is not necessary. The spring cap is rotatable by 360°, so that the pressure indicator is always visible. The pressure reducing valve type 315.2 complies with the European Standard EN 1567 and fulfils the DVGW requirements from DN 15 to DN 50 as well as the highest acoustic protection requirements up to DN

32. The pressure reducing valve type 315.2 is equipped with a spring-relieved single-seat valve and a coaxially positioned strainer (mesh width: 0.25 mm). The operational parts of the system are placed in a cartridge that can be exchanged without disassembling the whole valve and without using special tools; the outlet pressure setting remains unchanged. The special cartridge design allows for any mounting position.

Pressure reducing valve 315.2

Materials

The materials used for the SYR pressure reducing valve type 315.2 comply with the high requirements of European Standards. All synthetic parts getting into contact with water are approved by the German Public Health Office (KTW). The corrosion resistance in particular is guaranteed for all

used materials. The body is made of high quality hot-pressed brass. All rubber parts are made of ageing resistant elastomer. The diaphragm is reinforced and the high resistance of the screw cap is due to the glass fibre reinforced synthetic material.

Installation

The connection size depends on the required flow rate capacity. When choosing a pressure reducing valve, consider that a pressure drop of 1.1 bar occurs at maximum flow rate. This is the difference between the static and dynamic pressure at the outlet of the pressure reducing valve. When a specific flow rate is required for

a particular draw-off point, calculate the setting of the pressure reducer beforehand. A pressure reducing valve works without auxiliary energy with very little adjustment forces. Therefore, it reacts sensitively to impurities. A filter installed upstream effectively protects the pressure reducing valve type 315.2.

Thoroughly flush the pipe prior to installation. Mount the SYR pressure reducing valve type 315.2 in the pipe under consideration of the direction of flow (see arrow on the body) without applying

stresses. Afterwards, turn the head part without loosening the captive nut until the green outlet pressure indicator becomes visible.

Technical specifications

Inlet pressure:	max. 25 bar
Outlet pressure:	1.5 - 6 bar (factory set to 4 bar)
Service temperature:	max. 70 °C
Mounting position:	any
Medium:	water, compressed air, neutral non-adhesive fluids, neutral gases
Serial number:	0315...

Maintenance

The pressure has to be set at static pressure. Proceed as follows: loosen the safety screw in the adjustment knob. The requested pressure is set with a flick of the wrist. With the well-contrived outlet pressure indicator, the pressure reducer not only ensures the optimal pressure but also allows for reading the set pressure without an additional pressure gauge. To reduce the outlet pressure, turn the adjustment

knob in the direction of the minus symbol (-), to increase it, turn the adjustment knob in the direction of the plus symbol (+). It is recommended to carry out maintenance works on a regular basis to ensure durable functionality. The perfected design of the cartridge system allows to disassemble the pressure reducer's operational part without removing the whole valve and without using special tools.

Pressure reducing valve 315.2

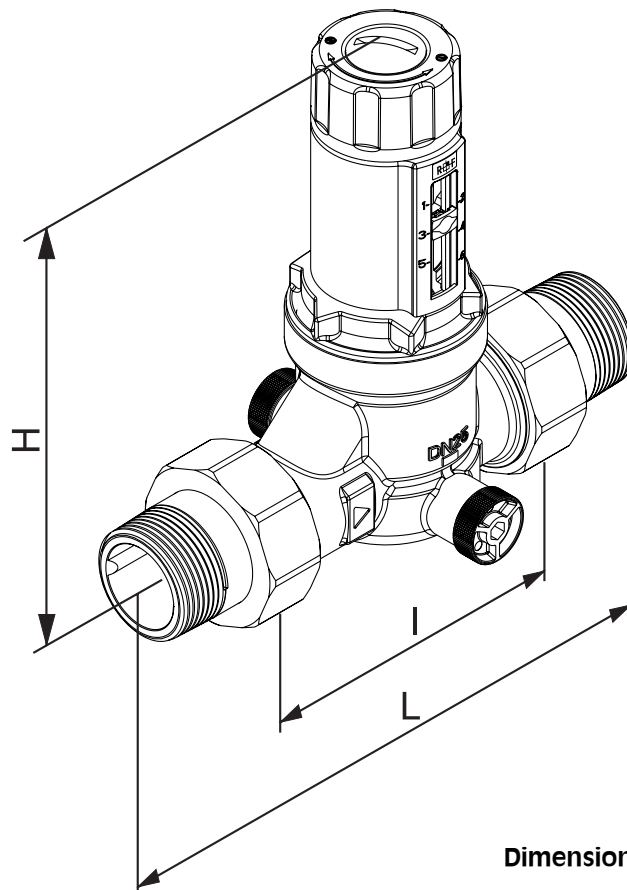

Soldered union

Dimensions without threaded union like D06F.

Nominal size		DN 15	DN 20	DN 25	DN 32	DN 40	DN 50
	A	G ½	G ¾	G 1	G 1 ¼	G 1 ½	G 2
Dimensions in mm	L (mm)	140	160	175	190	220	255
	I (mm)	80	90	100	105	130	140
	H (mm)	107	107	132	194	194	187
	Peak flow rate in m³/h (at 2m/s)	Residential buildings according to EN 1567	1,3	2,3	3,6	5,8	9,1
Peak flow rate in m³/h (at 3m/s)	Industrial/commercial buildings according to EN 806-2	1,8	3,3	5,4	8,6	13,7	21,2

Accessories

Pressure gauge: Type 11

Pressure reducing valve 315.2

Components / Order numbers

①
**Pressure reducer cartridge
with outlet pressure indicator**

②
Threaded union
composed of:
captive nut, union piece,
seal

DN 15	0812.15.900
DN 20	0812.20.900
DN 25	0812.25.900
DN 32	0812.32.900
DN 40	0812.40.900
DN 50	0812.50.900

③
Pressure gauge plug
0828.08.000

④
Body

